

VD101EP-V12L

650TVL WDR Day/Night Indoor Dome Camera



Key Features

- 1/3" Sony 960H Double Scan Super HAD CCD II
- Super High Resolution of 650TVL at Day / 700TVL at Night
- Super WDR(WDR+ATR)
- Easy-to-use OSD Functions
- 2D/3D DNR (Digital Noise Reduction)
- 2.8~12mm DC IRIS Lens
- Motion Detection
- RS-485(Pelco-D)
- 12VDC/24VAC Non-polarity Power Input
- Tool-free 3-Axis mechanism
- Additional service monitoring output
- Powerful Night Sensitivity

Perfect 3-Axis

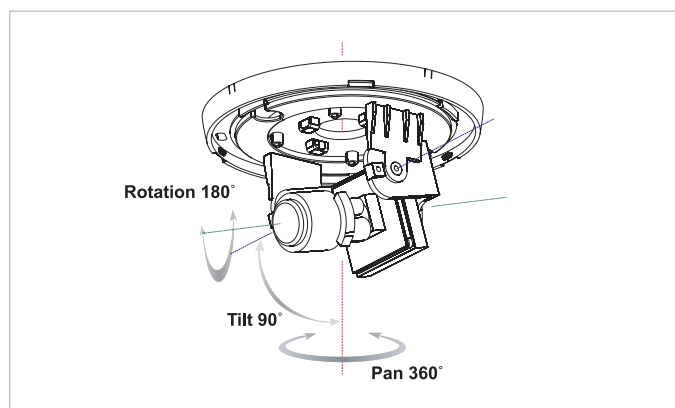

MODEL	VD101EP-V12L
Image sensor	1/3" Double Scan Super HAD CCD II (960H)
Effective Pixels	NTSC : 976(H) x 494(V) PAL : 976(H) x 582(V)
H. Resolution	650 TV Lines(Day) / 700 TV Lines(Night)
Synchronizing system	Internal
Scanning system	NTSC : 525 Lines PAL : 626 Lines 2:1 Interlaced
Video output	1.0Vp-p Composite 75 Ohms
S/N ratio	More than 50dB (AGC Off)
Min. Illumination	0.00001Lux(DSS), 0.05Lux(DSS Off) at F1.2
Shutter Speed	NTSC: 1/60~1/100,000 sec. PAL: 1/50~1/100,000 sec.
Gamma Correction	Standard $\gamma = 0.45$
White Balance	1,800°K ~ 10,500°K Auto ATW/PUSH/USER HOLD selectable by OSD
Gain Control	OFF/12dB/18dB/24dB/30dB/36dB/42dB/ 48dB/54dB/60dB
Smear Effect	0.005%
Power source	12VDC, 24VAC
Operating current	250mA at 12VDC, 150mA at 24VAC
Lens	2.8~12mm Varifocal DC Iris lens
MTBF	20,000 hours
Operating temp./Humidity	-10°C ~ 50°C (Humidity : 0%RH ~ 80%RH)
Measurement (mm)	134(Ø) x 91.7(H)
Weight (Approx.g)	500

Function	
WDR	Off/Auto1/Auto2(User select able by OSD)
White balance	ATW/PUSH/USER/HOLD/User selectable
Gain Control	Off/12dB/18dB/24dB/30dB/36dB/42dB/ 48dB/54dB/60dB
DNR	2D/3D DNR
Digital Slow Shutter	Off/2x ~ 512x (DSS)
Motion Detection	On/Off (4 Zones)
Privacy Mosaic	On/Off (4 Zones)
Digital Image Stabilizer	On/Off
Digital Zoom	Off/1.5x,2x,3x,4x Digital Pan/Tilt)

Perfect 3-Axis

